

HYDRAULIC EXCAVATOR

TB370

TAKEUCHI
From World First to World Leader



Product Features & Specifications

ENGINE

- EPA Tier 4 Final / EU Stage V
- Turbocharged
- DOC+DPF Exhaust After Treatment
- Automatic Fuel Priming System
- Dual Element Air Cleaner
- Working Modes; Standard and ECO
- Automatic Cold Start Device
- High Capacity Radiator and Hydraulic Oil Cooler
- Engine Safe Start System
- 90 Amp Alternator

UNDERCARRIAGE AND FRAME

- Triple Flange Track Rollers
- 2-Speed Axial Piston Travel Motors with Counterbalance Valves
- Integrated Load Sensing Automatic Shift Down
- Integrated Fail-Safe Mechanical Parking Brake
- Automatic Slew Brake with Shock-less Relief Valve
- Concealed in Frame Travel Motor Hoses
- High Torque Final Planetary Drives
- Heavy Duty Backfill Blade with Float
- Large Wrap-Around Counterweight
- Power Angle Blade (Optional)
- 15.7" Rubber Crawlers
- 15.7" Steel Crawlers (Optional)
- 15.7" Segmented Rubber Crawlers (Optional)

OPERATOR'S STATION

- Cab with Automatic Climate Control System
- Windshield Wiper and Washer
- Skylight with Sunshade
- AM/FM Radio with Bluetooth
- 8" Color Multifunction LCD Touchscreen Display
- Jog Dial with Multifunction Panel
- Multifunction Joystick Controls
- Hand Dial Electronic Throttle Control
- Rear View Camera
- Pilot Control Safety Lockout System
- ROPS/FOPS/OPG Level 1 Cab
- Deluxe High Back Suspension Seat
- Removable Washable Floor Mat
- Cup Holder
- Adjustable Arm Rests
- 12 Volt Power Socket
- 2' Retractable Seat Belt
- 3" Retractable Seat Belt (Optional)

TAKEUCHI FLEET MANAGEMENT

- 2 Year Standard Service
- Minimize Downtime
- Remote Diagnostics
- Utilization Tracking
- Proactive Maintenance
- Control Costs
- Geofencing

HYDRAULIC & WORKING EQUIPMENT

- Variable Displacement, Axial Piston Hydraulic Pump with Tandem Gear Pumps
- Closed Center, Load Sensing Hydraulic System
- Cushioned Boom and Swing Cylinders
- Boom Holding Valve with Integrated Lift Overload Alarm
- Hydraulic Pilot Controls
- High Flow Primary Auxiliary Circuit Plumbed to Mid-Arm with Shutoff Valves
- Secondary Auxiliary Hydraulic Circuit Plumbed to Mid-Arm with Shutoff Valves
- Integrated Hydraulic Attachment Quick Connect System (Coupler Optional)
- Automatic One-Way Flow Valve for Primary Auxiliary Circuit
- Automatic Auxiliary Circuit Pressure Release Feature
- Pilot Pressure Accumulator Valve
- Pilot Control Pattern Change Valve (ISO/SAE)
- LED Work Lights
- Travel Alarm
- Main Boom Cylinder Guard
- Long Arm with Integrated Thumb Mount
- Dual Pin Position Bucket (Optional)
- Hydraulic Pin Grabber Coupler (Optional)
- Mechanical Bucket Quick Coupler (Optional)
- Main Pin Hydraulic Thumb (Optional)



Large Floor with Foot Rest



Tilt Forward Cabin

TOUGH, POWERFUL, RELIABLE



8" Color Touch Screen Display



Jog Dial with Multifunction Panel



Rear View Camera



Radio and AC Control

With many advancements in performance and technology, the Takeuchi TB370 is designed to deliver exceptional functionality, power, and comfort. From its smooth, powerful, hydraulic system to its fully redesigned cab, the TB370 is built from the ground up for you, the operator, in mind.

Delivering the power you demand is a Kubota V2607-CR-TE5B turbocharged diesel engine that is EPA Tier 4 Final compliant, produces 56.8 hp and over 165 ft-lb of torque. Matched to the engine is a closed loop, load sensing hydraulic system that makes the TB370 an excellent attachment platform. First, second, and third auxiliary circuits are plumbed to mid-arm with the primary circuit providing over 31 gpm enabling you to run a wide range of powerful, hydraulically driven attachments. The second auxiliary circuit will provide you with a dedicated thumb circuit, and the third circuit will allow you to install a hydraulic pin grabber coupler for the quick and easy exchange of various attachments.

The cabin on the TB370 provides you with commanding views of the job-site thanks to the large windows and rear-view camera. An 8" touchscreen color monitor and jog dial put you in complete control of a wide range of functions that include the HVAC system, AM/FM radio with Bluetooth, hydraulic flow rate settings and attachment presets. Additional functions are provided via the one touch panel that allows you to choose features like auxiliary detent, LED work lights on/off, lift overload alarm, rear-view camera on/off, and ECO mode.

Your daily maintenance inspections are simple to perform as both the engine and right-side hood open overhead providing access to the engine oil filter, engine oil dipstick, engine oil fill, fuel filter, fuel water separator, fuel tank, hydraulic tank, hydraulic oil sight gauge, and cooling module. The TB370 also features a forward tilting cab that provides access to the control valve and backside of the engine.



Deluxe Interior with 8" Color Touchscreen Monitor and Intuitive Controls

OPERATING PERFORMANCE

Operating Weight	14,850 lb	(6,735 kg)
Slew Speed	8.8 rpm	(8.8 min ⁻¹)
Travel Speed		
1st	1.6 mph	(2.5 km/h)
2nd	2.9 mph	(4.7 km/h)
Gradeability	30°	
Ground Pressure	5.4 psi	(37.0 kPa)
Max Bucket Breakout Force	14,613 lb	(6,628 kg)
Max Arm Digging Force	6,609 lb	(2,998 kg)
Traction Force	16,479 lb	(7,475 kg)
Boom Swing Angle (Left/Right)	79°/51°	

HYDRAULIC SYSTEM

Auxiliary Flow - Primary Circuit	31.7 gpm	(120.0 Lpm)
Auxiliary Flow - Secondary Circuit	12.3 gpm	(46.6 Lpm)
Hydraulic System Pressure	3,550 psi	(24.5 MPa)

ENGINE

Make / Model	Kubota V2607-CR-TE5B	
Displacement	159.6 cu in	(2,615 ml)
Horsepower @ 2,200 rpm	56.9 hp	(42.4 kW)
Maximum Torque @ 1,500 rpm	168.1 ft-lb	(227.9 Nm)

FLUID CAPACITIES

Engine Lubrication	9.5 qt	(9.0 L)
Cooling System	11.6 qt	(11.0 L)
Fuel Tank Capacity	29.0 gal	(110.0 L)
Hydraulic Reservoir Capacity	17.3 gal	(65.5 L)
Hydraulic System Capacity	36.7 gal	(139.0 L)



Wide Opening Service Hoods



Hydraulic Pilot Controls





1st, 2nd, 3rd Auxiliary Lines



LED Work Lights

TB370 Lifting Capacities at Ground Level*

Lift Point Radius from Rotation Axis	9' 9.6" (2,743 mm)		18' 4.4" (5,598 mm)	
 Lifting Capacities Over Front, Blade Down	7,575 lb	(3,436 kg)	3,129 lb	(1,419 kg)
 Lifting Capacities Over Side	4,273 lb	(1,938 kg)	1,782 lb	(808 kg)

* Ratings based on ISO10567 and do not exceed 87% of hydraulic lift or 75% of tipping load.

ATTACHMENTS

Takeuchi now offers attachments for all of your Takeuchi equipment. See your authorized Takeuchi dealer for additional information and attachment options.

TB370 Compact Excavator

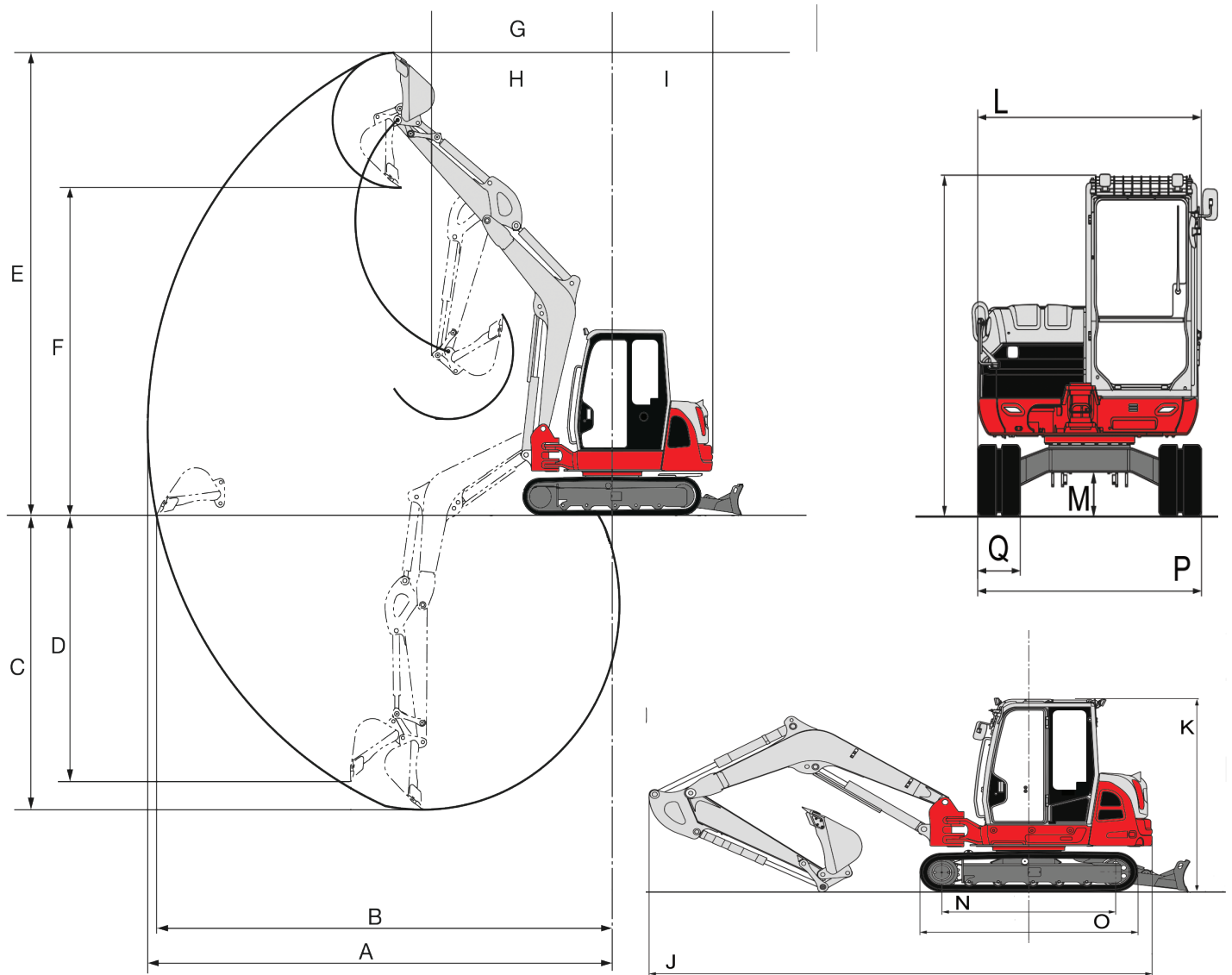

MACHINE DIMENSIONS

A	Maximum Reach	21' 11.4"	(6,690 mm)
B	Maximum Reach at Ground Level	21' 6.4"	(6,565 mm)
C	Maximum Digging Depth	13' 4.7"	(4,085 mm)
D	Maximum Vertical Digging Depth	12' 6.2"	(3,815 mm)
E	Maximum Height of Cutting Edge	21' 0.7"	(6,420 mm)
F	Maximum Dumping Height	14' 11.0"	(4,545 mm)
G	Front Swing Radius	8' 5.5"	(2,580 mm)
H	Front Swing Radius with Boom Offset	6' 8.3"	(2,040 mm)
I	Slew Radius	4' 9.4"	(1,455 mm)
J	Transport Length	19' 5.2"	(5,925 mm)
K	Transport Height	8' 4.0"	(2,540 mm)
L	Upper Structure Overall Width	6' 10.5"	(2,095 mm)
M	Ground Clearance	13.2"	(335 mm)
N	Track Base	6' 8.8"	(2,050 mm)
O	Track Overall Length	8' 5.4"	(2,575 mm)
P	Track Overall Width	6' 10.7"	(2,100 mm)
Q	Track Width	15.7"	(400 mm)



2 YEAR
2,000 HOUR
FULL MACHINE
WARRANTY



© 2021 Takeuchi Manufacturing (U.S.), Ltd. All Rights Reserved. Printed in the U.S.A.
In accordance with our established policy of continued improvement, specifications and features are subject to change without notice. Pictures may show options other than standard equipment.

FORM: TB370 Compact Excavator Spec Sheet - Mar. 2021

TAKEUCHI
From World First to World Leader